

# EMCO SPECIALTY PRODUCTS, INC.

408 MIAMI AVE. KANSAS CITY, KS 66105 - 913-281-4555 / FAX. 913-281-4554

## H1 COAT RACK INSTALLATION INSTRUCTIONS

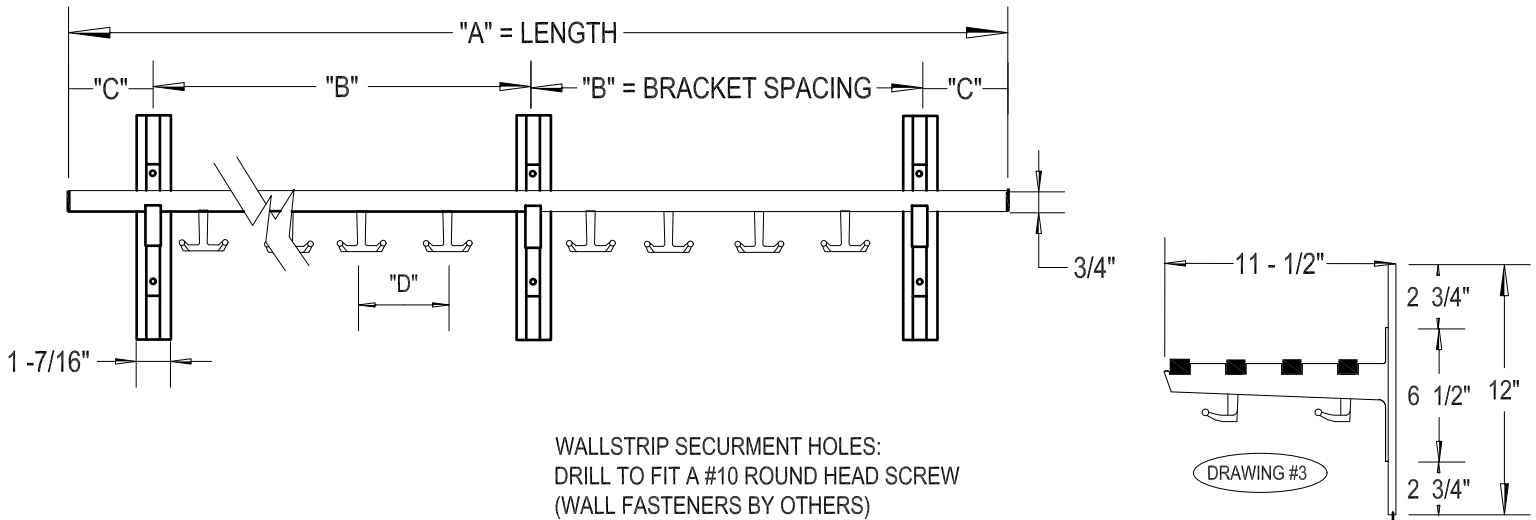

1. DETERMINE LOCATION AND HEIGHT OF WALL STRIP ( SEE NOTES ON SUGGESTED HEIGHT).
2. MARK LOCATION OF WALL STRIP ON THE WALL USING A CARPENTERS LEVEL TO ENSURE THEY ARE INSTALLED AT THE SAME LEVEL AND PERPENDICULAR TO THE FLOOR. BRACKET SPACING "B" IS LISTED ON THE CUSTOMER COPY OF THE PICKING TICKET AND MUST BE ADHERED TO FOR PROPER SHELF SUPPORT.
3. PREPARE HOLES AND MOUNT AS FOLLOWS: (FASTENERS BY OTHERS - SEE DRAWING #1).

A. FOR WALLS WITH WOOD STUDS - PREDRILL A 5/32" HOLE 1 1/2" DEEP AND ATTACH WITH #10 X 1 3/4" PAN HEAD WOOD SCREW.

SUGGESTED HEIGHT TO FIN. FLR.  
42" THRU 5th GRADE, - 60", 6th THRU ADULT

B. FOR WALLS OF HOLLOW MATERIAL SUCH AS TILE - USE 3/16 SPRING WING TOGGLE AND ATTACH WITH 10-24 X 3" PAN HEAD BOLT.

C. FOR WALLS OF SOLID MATERIAL SUCH AS CONCRETE, BRICK, STONE, ETC, USE A #10 DEDICATED MASONRY SCREW A MINIMUM OF 1 1/2" LONG.

4. INSERT THE ROUND BASE WELD NUTS THROUGH THE 2 BRACKET HOLES (SEE DRAWING #2). SCREW IN THE 10-24X5/8" PHIL PAN HEAD SCREWS. DON'T LET THE SCREW POINT PROTRUDE BEYOND THE WELD NUT BASE. POSITION BRACKET IN THE PRE HUNG WALL STRIP AND TIGHTEN BRACKET SCREWS.

DO NOT OVER TIGHTEN THE SCREW AS IT MIGHT SHEAR THE SCREW HEAD. (IF THE WELD NUT BASE STARTS TO SPIN DURING TIGHTENING, INSERT A FLAT HEAD SCREW DRIVER UNDER THE BASE TO PREVENT MOVEMENT).

5. THE SHELF UNIT IS COMPOSED OF 2 PLAIN SLAT AND TWO SLAT WITH HOOKS. THE HOOKED SLAT IS INSERTED IN THE SECOND AND FOURTH SLOT OF THE BRACKET AND THE PLAIN SLAT GOES INTO THE FIRST AND THIRD SLOTS. (REFER TO DRAWING #3). SECURE IN PLACE BY INSERTING A #10 X 1 3/4" SCREW IN THE CORRESPONDING HOLE UNDER THE BRACKET AND TIGHTEN WITH A PHILLIPS HEAD SCREWDRIVER. WHEN TIGHTENING SLAT IT SHOULD BE HELD TIGHT AGAINST THE BRACKET. THIS WILL INSURE PROPER SEATING. YOU MAY HAVE TO ADJUST THE POSITION OF THE HOOK SLAT SLIGHTLY SO THAT IT CLEARS THE BRACKET.

**CAUTION: DO NOT OVER TIGHTEN THE SCREWS SECURING THE SLAT AS IT WILL STRIP THE SCREW AND PREVENT IT FROM HOLDING THE SLAT IN PLACE.**

6. INSERT WALL STRIP END PLUGS AND CLEAN ENTIRE SHELF WITH A SOFT CLOTH.

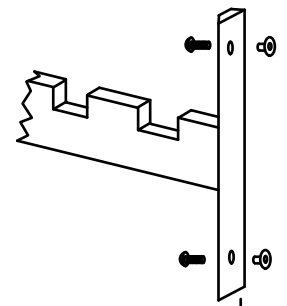
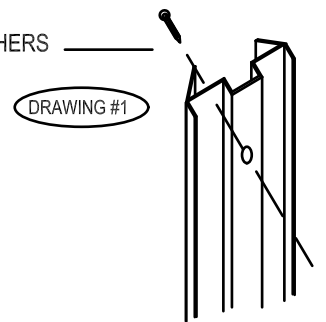
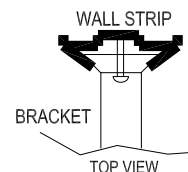

DRAWING #2